

---

## 7 It's the right moment to embrace the Minsky model

*Robert J. Barbera and Charles L. Weise*

---

### **Introduction**

US monetary policy from 1979 through 2000 delivered the world an important victory. The Paul Volcker/Alan Greenspan eras broke the back of the wage-price inflation dynamic that crippled the global economy in the 1970s. That victory was, however, misunderstood by mainstream economists. The defeat of the *Great Inflation* led to proclamation that the US had achieved a *Great Moderation*. Trade cycle worries, the story went, had been substantially reduced. Intelligent policymakers, corporate heads and investors would do best if they focused on long term issues. Boom and bust cycles remained, but their amplitudes were small and their likely appearance rare – so stick to the long term and you were likely to be on the right road.

Excitement about the *Great Moderation* elevated the status of the Federal Reserve Board. At the White House conference on the new economy, held on 4 April 2000, Alan Greenspan sat alongside President Clinton. In the eyes of most conference participants Alan Greenspan, not President Clinton, was the celebrity – the Maestro, as Bob Woodward called him.

Times change. As the first decade of the new millennium winds down, Ben Bernanke, the new Fed Chairman, is under intense scrutiny. The Chairman and his colleagues from mid-2007 through fall-2008 have confronted clear evidence of substantial US economic retrenchment laid alongside building inflationary pressures. Most commentators acknowledge that 2008 will likely be labeled a recession once official arbiters have a complete picture of the year's economic performance.

The crisis has unfolded in the credit markets. Over the twelve months ending mid-2008 the Fed felt compelled to engineer a forced merger for Bear Sterns, and award all investment banks access to the discount window. In addition, the US treasury was forced to put Fannie Mae and Freddie Mac under Federal control. These extraordinary steps were taken in response to the metastasizing problems tied to lending practices in the US residential real estate market. With the benefit of hindsight, it became clear that many US financial services companies spent several years

writing home mortgages that depended upon rising home prices. Once house prices reversed direction the colossal US real estate edifice began to crumble, taking financial markets along with it.

This chapter will make the case that Alan Greenspan and more generally US Fed policymakers failed to award asset prices their just due between 1998 and 2008. During quiescent moments Fed officials embraced the standard orthodoxy that market prices provide the best guess available about the future. Alan Greenspan, in particular, emphasized that the Fed *had no ability to out guess the market*.

During financial system mayhem, however, Fed policymakers were compelled to do just that. By their actions Fed policymakers revealed that they understood the dangers that arise during Minsky Moments. To calm financial waters, without acknowledging Minsky insights, Fed policymakers established a practice of treating such events as 'special circumstances'. They have been labeled 'liquidity crises' or 'confidence crises'. Fed policymakers were then free to treat these events as isolated developments requiring unusual, one-time, divergences from the normal conduct of monetary policy. Fed officials, in effect, only embraced Minsky insights 'in the moment'.

The Fed's ad hoc strategy introduced a fundamental asymmetry into monetary policy. This asymmetry contributed to the process that put the US financial system, mid-2008, on very shaky ground. An explicit focus on financial markets, both on the way up and on the way down, is long overdue. Monetary policy will improve if it treats asset markets symmetrically. In other words, the Fed must stop merely responding to Minsky Moments and begin to conduct monetary policy consistent with the Minsky model.

To make the case for thinking about Minsky notions throughout the business cycle, this chapter first documents the poor predictive powers of standard Taylor rule equations over the past 10 years. We then suggest three successive adjustments to Taylor's Equation. The final equation we offer up, a Minsky/Wicksell modified Taylor rule (MWMTR) captures important swings in monetary policy over the past 10 years. The MWMTR, however, fails to capture all monetary policy swings. Why? Because Fed policy, 1998–2008 was wildly asymmetric in its treatment of asset prices.

We introduce a macroeconomic framework that rationalizes the MWMTR. We argue that the right way to think about monetary policy involves mapping out the dynamics between a changing fed funds rate, shifting risky real rates and evolving expectations about real economy investment opportunities. Our critical conclusion? Changing risk appetites over the course of the business cycle materially affect borrowing costs for

real economy investment, and Fed policy needs to take account of these shifts throughout the business cycle.

### **Rules are for fools?**

H.L. Mencken once remarked that ‘for every problem, there is a solution that is simple, neat, and wrong’ (Mencken 1927). He could easily have been talking about economists’ pursuit of a one size fits all rule to guide monetary policy. We all know the ideological motivation behind efforts to make monetary policy automatic. Free markets, mainstream economic theory insists, will get us where we need to go. Ergo, the less room for meddling by the central bank, the better. And we also know why central bankers speak respectfully about rules. When they judge that policy needs to move in a politically unpopular direction, they can find some cover by claiming that the decision was ordained by a rule.

Paul Volcker, a giant among central bankers, brilliantly exploited this trick. When Volcker took over in August of 1979 he announced that money supply growth targets would dictate open market operations. By declaring that the Fed was eschewing interest rate targets for money growth trajectories Volcker could claim, with a straight face peering out from a waft of cigar smoke, that the ensuing spectacular rise for interest rates was an unfortunate burden, but one that he had no immediate way to remedy – given his need to adhere to his self-imposed money target straitjacket.

After the collapse of any recognizable linkage between money stock growth rates and growth rates for nominal economy trajectories, Stanford’s John Taylor came to the rescue. The Taylor Rule arrived in the early 1990s. Taken literally, it says that central bankers have a new way to put monetary policy on autopilot – the end of money stock targeting notwithstanding.

### *The Taylor Rule and headline versus core inflation*

John Taylor’s elegant equation roughly reproduced Fed policy decisions over the 1987-93 years with a bare minimum of explanatory variables. But as H.L. Mencken reminds us, life is never simple. And the Taylor Rule’s record, from the late 1990s years, has been very spotty.

The 1998–2008 track record for Taylor’s original equation (we make one modification to Taylor’s equation, replacing the potential/actual GDP deviations with the Non-Accelerating Inflation Rate of Unemployment (NAIRU)/actual unemployment divergences (see Appendix)) is presented in Figure 7.1. Clearly, the Taylor Rule had a tough 10 years. Part of the problem reflected the wild swings for energy prices registered from 1998 through 2008. Oil prices plunged, falling below \$10 per barrel, in mid-



*Figure 7.1 The Taylor rule fails, as surging and volatile energy prices implied volatile and very high, federal funds rates*

1998. This had the effect of driving headline inflation well below the core rate. Sharp leaps for oil prices, in contrast, were the rule over the first eight years of the new decade, with oil prices mid-2008 near \$150 per barrel. This wild ride for energy prices put headline Consumer Price Index (CPI) changes into volatile territory. Taylor Rule calculations, as Figure 7.1 shows, called for volatile swings for fed funds despite more muted swings for underlying price pressures. Fed policymakers, in response, elevated the importance of core inflation. As a consequence, as Figure 7.1 makes obvious, an equation predicting the funds rate that depended upon headline inflation looked for more volatile swings for the funds rate. Moreover, on average it looked for substantially higher funds rate, over the last eight years.

Nonetheless, as Figure 7.2 reveals, a Taylor Rule federal funds trajectory using the core CPI also does a poor job of catching actual swings in the overnight rate. In particular, a core CPI generated Taylor Rule fails to anticipate the intensity of late 1990s tightening. It fails to predict aggressive Fed ease in 2001 to 2002. And quite spectacularly, both the core CPI Taylor Rule and a Taylor Rule using headline CPI, from fall 2007 through spring 2008, fail to anticipate the dramatic ease put in place by the Bernanke-led Fed.

Indeed, blind faith in the Taylor Rule, or a Core CPI modified Taylor rule, could lead one to the conclusion that Fed policymakers lost their minds in late 2007 early 2008. It is instructive, therefore, to reflect upon the fact that mainstream commentators in the world's financial markets came

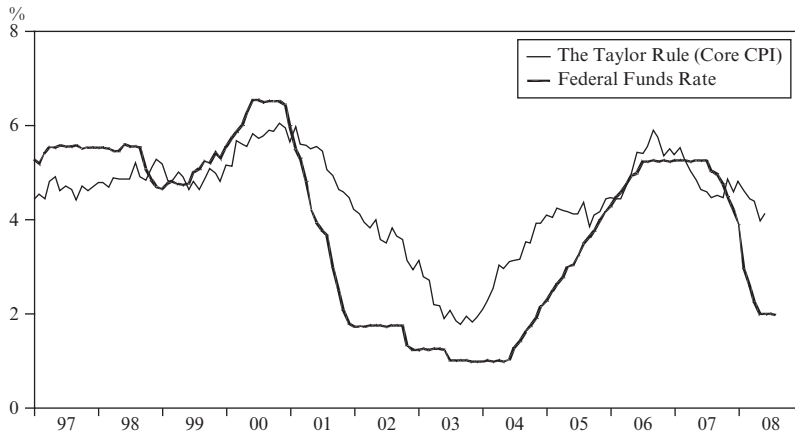

Figure 7.2 *A core CPI Taylor rule, in contrast, is slow to anticipate moves to ease*

to a common explanation for the plunging fed funds rate through spring 2008. In the *Economist*, in the *Wall Street Journal*, the *New York Times* and of all places the *New Yorker* (see Figure 7.3), it was acknowledged that aggressive Fed ease was unfolding because the Minsky Moment had arrived.

#### **From rules are for fools to our rule is better than your rule**

The power of the Minsky Moment, in the eyes of the many, to predict Fed policy invites a simple question. Can we redefine the Taylor Rule in a fashion that captures Minsky Moment insights and therefore does a better job of tracking the funds rate over the past 10 years? After all, it is easy to scoff at one line equations that purport to capture all essential information needed to divine monetary policy moves. But in the current climate of retrospective thinking about the Greenspan years, reconstructing the Taylor rule, imbuing it with Minsky-like insights, could well prove instructive. Thus, as a vehicle for retrospective analysis, we offer up the MWMTR. This equation, a reworking of Taylor's effort, does a much better job of explaining the past 10 years of fed funds movements. And it does so, mostly, by including a term in the equation for Minsky Moments.

But the equation delivers more than that. It is our contention that the MWMTR reveals that US monetary policy, for at least a decade, has been clearly schizophrenic. Once we remind ourselves of Fed policymaker justification for responding as they do during Minsky Moments, we lay bare the Fed's conflicted stance toward financial markets. Simply put,



*Source:* Reproduced by kind permission of the artist.

*Figure 7.3* Illustration by Tom Bachtell, originally published in *The New Yorker*, 4 February 2008

our equation confirms what many commentators have noted. Fed actions 1998 through 2008, responded to flights of anguish, but ignored flights of fancy. And part of the wreckage in place in 2008 can be laid at the doorstep of that unambiguous inconsistency, and the moral hazard that it helped to create.

What did we do to the Taylor rule to make it confess? We made two adjustments, one quite palatable to mainstream economic thinking, the other controversial. Our two adjustments look to market estimates for neutral real short rates and to market attitudes about tail risks. In combination they allow us to roughly reproduce 10 years of Fed policy and, at the same time to reveal one profound inconsistency.

#### **From the number '2' to a Wicksellian neutral real short rate**

Taylor's initial equation included a term for the neutral real short-term interest rate. In one of the grandest economic generalizations imaginable, Taylor embraced one value for this economic variable. The neutral real short rate, he decided, was '2'. How does '2' stand up to the past 100 years of US economic history? As Table 7.1 reveals, it has mostly been honored

Table 7.1 *Real short rates: neighborhoods shift over time*

	Inflation	Interest rate	Real rate
1920–29	1.0	3.8	2.8
1930–40	–5.0	0.6	5.6
1941–54	4.7	0.9	–3.8
1955–65	1.4	2.9	1.5
1966–74	5.6	5.6	0.0
1975–80	8.8	6.3	–2.5
1981–90	4.5	7.7	3.2
1991–2000	2.7	5.0	2.3
2000–07	2.7	3.0	0.3

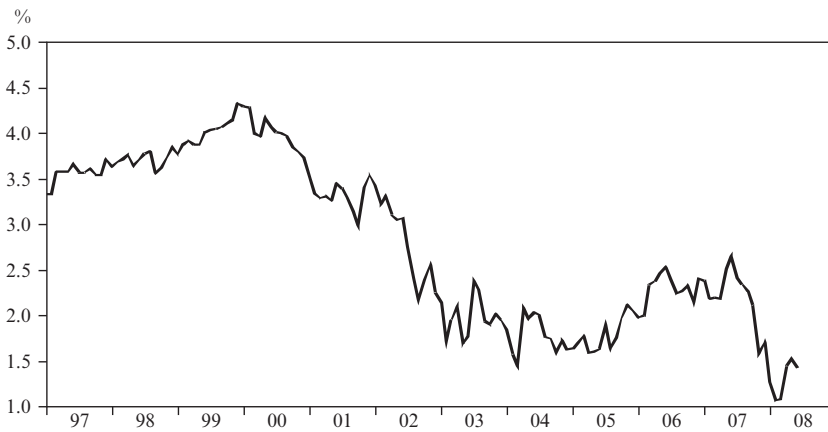

Figure 7.4 *The long-term TIPS yield: a window on volatile real return expectations, clouded by monetary policy decisions (TIPS yield, 10-year)*

in the breach. Attitudes about long-term trajectories for economic growth, long term real return opportunities for investors and regulatory regimes clearly change over time. In response, the average real short rate has changed, more times than not, from economic cycle to economic cycle.

With the advent of Treasury Inflation Protected Securities (TIPS) bonds we now have the ability to extract changing market opinion about long-term real return opportunities. The easiest way to get a fix on real return expectations is to look at the yield on 10-year TIPS (see Figure 7.4). We need to remind ourselves, however, that if we believe monetary policy matters, we must expect that it operates via financial markets. That,

in turn means that the yield on 10-year TIPS is influenced by the Fed determined overnight interest rate. We can view the 10-year TIPS yield as a blend of expectations about Fed-engineered real short rates and the market's evolving sense of what constitutes an equilibrium real long-term interest rate.

Fed policymakers confront a similar issue when they look to TIPS instruments as indicators of long-term inflation expectations. The Fed's preferred long-term inflation indicator is teased out of TIPS bonds of different maturities. Taking a page out of the Fed's playbook, we infer the five-year forward real yield, by subtracting the five-year TIPS yield from the 10-year TIPS yield. We assert, further, that the five-year forward TIPS yield is largely free of short run Fed policy expectations.

The five-year forward TIPS yield gets us close to a market measure of the Wicksellian natural rate. We simply need to add a spread term to the inferred TIPS rate and we have a real time estimate of the Wicksellian long rate. Over the 1960 through 2008 period the spread between Baa corporate bonds and treasury 10-year notes has been 1.8 percentage points. We therefore add 1.8 percentage points to our five-year forward yield and we have an estimate at any moment for the Wicksellian neutral real long rate.

We posit that the neutral real risk free short rate relates directly to the capital market determined Wicksellian natural long rate. If the world comes to believe that the natural real long rate is 7 per cent, up from 5 per cent, clearly the neutral real fed funds rate will be higher in that world as well.

We propose that you can estimate the value for the neutral real short rate simply. Return to the implied equilibrium risk free real long rate – by subtracting the spread term from the Wicksellian rate – and subtract an estimate of the average term premium. This simply adjusts for the fact that the yield curve, historically, exhibits a positive slope. We use the average term premium from 1960 through 2008, 82 basis points.

We now have a capital markets determined assessment of the neutral real short-term interest rate. We use it to replace Taylor's static value of '2'. In symbolic terms, we replace '2' with ' $W - (\tau + \sigma)$ ' (see Appendix). Figure 7.5 tracks the measured neutral real short rate over the 10 years.

What does invoking Wicksell and the natural rate notion afford us? Replay the late 1990s Brave New World euphoria. Greenspan and other members of the Federal Open Market Committee (FOMC) noted that the boom in technology investment had lifted notions of sustainable real growth, real investment opportunities, and equilibrium real risk free long rates. Accordingly, they went on, the neutral risk free rate had likely moved higher. By replacing the number '2' with ' $W - (\tau + \sigma)$ ' we have a



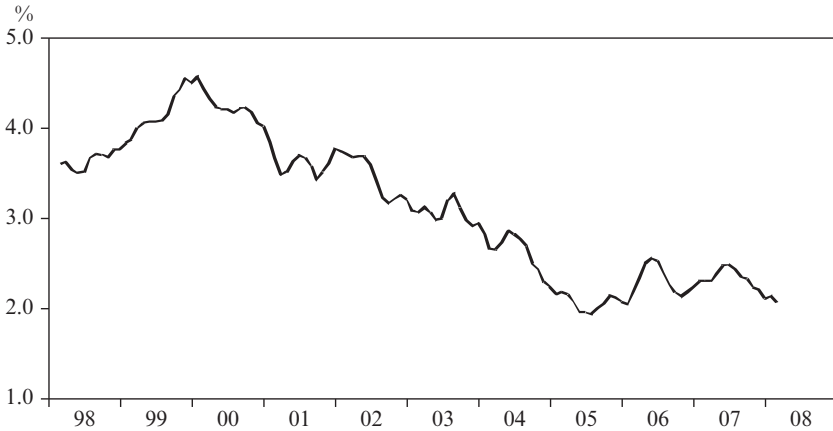

*Figure 7.5 The forward TIPS yield: exuberant, amid the 1990s technology boom, plunging amid tech bust-cum 'global savings glut' (TIPS yield, 5-year forward)*



*Note:* Wicksell rates. Jan.–July or 1997 are estimated. No TIPS existed, therefore interpolation was necessary.

*Figure 7.6 The Wicksell modified Taylor rule anticipates late 1990s tightening, but systematically misses big ease*

market driven measure of the neutral real short rate. A core CPI Taylor Rule with this adjustment tracks the tightening regime that unfolded in 1999 through 2000 more closely than does the traditional Taylor equation (see Figure 7.6).



*Figure 7.7 Risky–risk free credit spreads: a critical input for monetary policy, corporate bond yield, BAA minus 10-year treasury note yield*

**What’s missing? Minsky insights, compliments of risky/risk-free spreads**

What remains to be explained, of course, are the moves to ease, in 1998, 2001 through 2002, and mid-2007 through mid-2008. What prompted the Fed to ease in each of these cases, in conflict with standard Taylor rule calculations? Panic in asset markets led Fed officials to conclude that risks to the financial system were large and growing. Attending these financial system risks were increasing concerns about the potential for extremely unfavorable real economy developments. Thus ‘fat tails’ in periods of mayhem, invite aggressive ease.

As a simple proxy for the state of fear in the system, we enter our Minsky term, credit spreads (see Figure 7.7). We compare treasury and BAA yields. We label 180 basis points a neutral credit spread. Deviations from the neutral spread justify changes in the target funds rate.

How does our MWMTR perform? As Figure 7.8 reveals, the revised formula does pretty well. It captures the tightening in 1999 through 2000, compliments of the Wicksell term. It looks for ease in 1998 and big ease, 2001 through 2002. Most tellingly, it does an excellent job of anticipating the 2007 through 2008 moves to easier money, a feat that the Wicksell modified Taylor Equation fails to perform.

As importantly, however, the MWMTR looks for the Fed to begin normalizing interest rates starting in the middle of 2003, a full year before

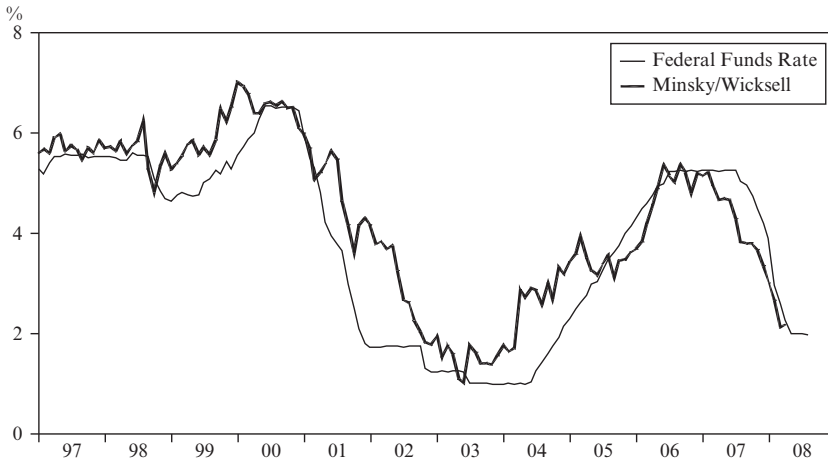

*Note:* Wicksell rates. Jan.–July or 1997 are estimated. No TIPS existed, therefore interpolation was necessary.

*Figure 7.8 The Minsky/Wicksell modified Taylor rule: a better fit for the past two cycles*

the Fed actually began raising rates. Does that mean the MWMTR is fundamentally flawed? We think not. Instead we think it is the conduct of monetary policy, over the ten-year period that has been flawed – a consequence of acknowledging Minsky Moments instead of embracing a Minsky model.

#### **Replacing IS/LM curves with IS/TS curves**

It is at this point in our story that we think it becomes important to tie some simple macro theory to swings in the Wicksell and Minsky terms. To that end we need to explicitly, if somewhat simplistically, describe the Fed's money transmission mechanism. The model we sketch out here is described in more detail in Weise (2007) and Weise and Barbera (2009).

We start by accepting the New Keynesian notion that the Fed sets the nominal short rate with an eye toward influencing the risky real long rate. The real risk-free long rate is a weighted average of the current federal funds rate adjusted to account for a term premium, and the Wicksellian natural risk-free rate of interest. This formulation, which is derived in the papers cited above, is consistent with the expectations theory of the term structure of interest rates:

$$R = \omega(f + \tau) + (1 - \omega)W$$

where  $r$  is the risk-free real long-term interest rate,  $f$  is the real federal funds rate,  $\tau$  is a constant term premium, and  $W$  is the risk-free Wicksellian natural rate of interest. The real long-term interest rate is affected by the current federal funds rate through the first term. The second term embodies the assumption that in the long run the real long-term interest rate is expected to be equal to the Wicksellian rate, which anchors the long end of the term structure. Then  $\omega$  is a weighting factor reflecting the length of time (relative to the term of the long-term bond) that interest rates are expected to depart from their long-run expected level. We define the neutral real federal funds rate to be the rate that corresponds to the Wicksellian rate.

$$f^* = W - \tau$$

According to the above equation, when  $f = f^*$ ,  $R = W$ .

The real risky long-term interest rate is the risk-free rate plus a risk premium or credit spread term. Letting  $S$  be the spread term, we can write

$$S = \sigma + \eta$$

where  $\sigma$  is the mean value of  $S$  (assumed constant) and  $\eta$  is a stochastic credit spread 'shock' term with mean zero. Adding  $S$  to both sides of the equation for the risk-free rate and rearranging gives us an equation relating the real risky long-term rate of interest to the real federal funds rate and the Wicksellian natural risky rate of interest:

$$r = \omega(f + \tau + \sigma) + (1 - \omega)W^* + \eta$$

where  $r = R + S$  is the real risky long-term interest rate and  $W^*$  is the real risky Wicksellian natural rate. We refer to this equation as the TS equation.

The second half of the model, the IS curve, is conventional: the output gap is negatively related to the difference between the real risky long-term interest rate and the (risky) Wicksellian natural rate:

$$y = a - b(r - W^*)$$

where  $y$  is the output gap,  $a$  is autonomous expenditures, and  $b$  represents the sensitivity of demand to changes in the interest rate.

We can use a graphical depiction to present, in stylized fashion, the events that transpired from 1999 through 2000. In 1999 much of the globe embraced the notion that the US had embarked upon a Brave New World

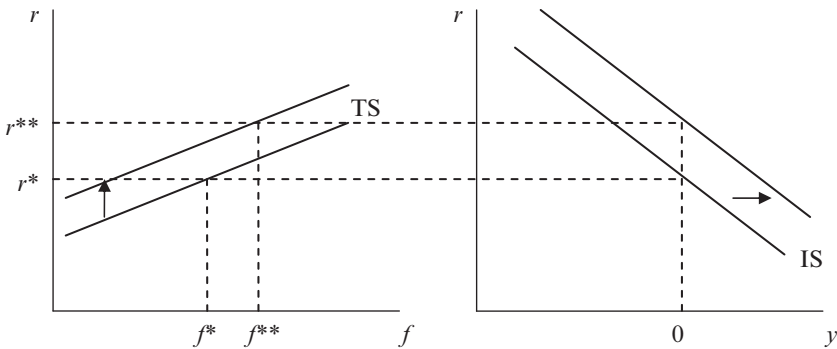

Figure 7.9 *Brave new world*

of technology driven boom. This Wicksellian event was reflected in a sharp shift to the right for the IS curve and an upward shift for the TS curve.

Again, the IS curve shifts to the right. This straightforwardly reflects a shift in expectations as people come to believe that the Brave New world (BNW) offers up substantially improved investment opportunities at a given interest rate.

Simultaneously, the TS curve shifts upward. How so? Refer back to Figure 7.5. The equilibrium Wicksellian rate climbs sharply, late in the 1990s, a function of the belief in expanded investment opportunities and higher real growth rates. This, directly, lifts the TS curve.

This BNW technology shock is captured by both our Taylor Rule equation and in our IS/TS graphical depiction (see Figure 7.9). IS shifts to the right. TS shifts upward reflecting rising  $W$ . Fed raises  $f$  from  $f^*$  to  $f^{**}$ . Both  $r^*$  and  $f^*$  are higher.

What does this imply for the Fed? The federal funds rate rises as the neutral real short rate climbs with the Wicksellian neutral rate. And much to the delight of efficient market theorists, the Fed does best by simply following the market's lead. Do what the TIPS yield tells you, in a Wicksell modified Taylor Rule, and you get to the right place (see Figure 7.6).

Now, however, we need to explain the swoon for federal funds, visible in 2001 through 2002 and again, mid-2007 through mid-2008. We begin with the 2001 through 2002 experience. When the BNW notion went bust financial markets began to violently re-price. What happened to the market's notion of equilibrium real interest rates? Look again at Figure 7.5, our imputed  $W$  falls reflecting newfound pessimism about investment opportunities. This drop for  $W$  can be interpreted as a shift left for the IS curve.

What about the TS curve? In a world in which central bankers had an

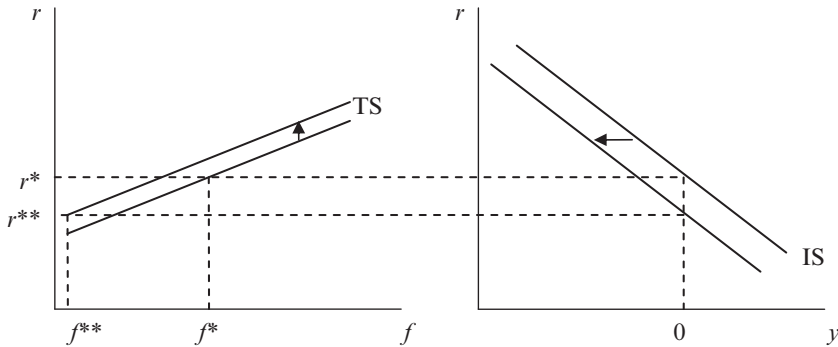

Figure 7.10 Minsky moment

easy life the TS curve would shift down sharply, lowering the risky real long rate and signaling to the Fed that the funds rate needs to fall commensurately. But we live in no such place. Instead we operate in a system where major disappointments, at business cycle turning points simultaneously drive real return expectations *and* risk appetites sharply lower. As a consequence, the risky real rate rises even as the conventional wisdom comes to believe that investment opportunities have fallen precipitously. In other words, the TS curve shifts upward just as the IS curve has shifted to the left compliments of surging risky/risk free spreads (see Figure 7.7). And that, of course sets the economy and the markets up for an adverse feedback loop that can end in catastrophe (see Figure 7.10).

Except, of course, that since the 1930s, 'It' hasn't. Why not? The answer, with all due respect to Mencken, is simple. The Fed understands its role as lender of last resort. In our diagram, the Fed recognizes that the sharp widening of spreads implies a sharp shift leftward for the IS curve, and it knows that it needs to ease with abandon to counter sharp spread widening and get risky real rates lower (see Figure 7.10). IS shifts left, TS shifts up because rise in spread exceeds fall in  $W$ . Fed recognizes fall for  $W$  has not lowered risky rate. Fed eases aggressively.

### From macro theory to monetary policy critique

We like the fact that our MWMTR does a reasonable job of capturing the Fed's reactions during Minsky Moments. But the depiction tells us more. Greenspan's commentary, in both 1998 and 2001, amounts to labeling market moves as driven by 'unwarranted fears'. That sounds to our ears like an act of heresy for someone who embraces the wisdom of markets. And our simple diagram reveals that taking your cue from market implied neutral risk-free rates – a passive Wicksellian approach – is doomed

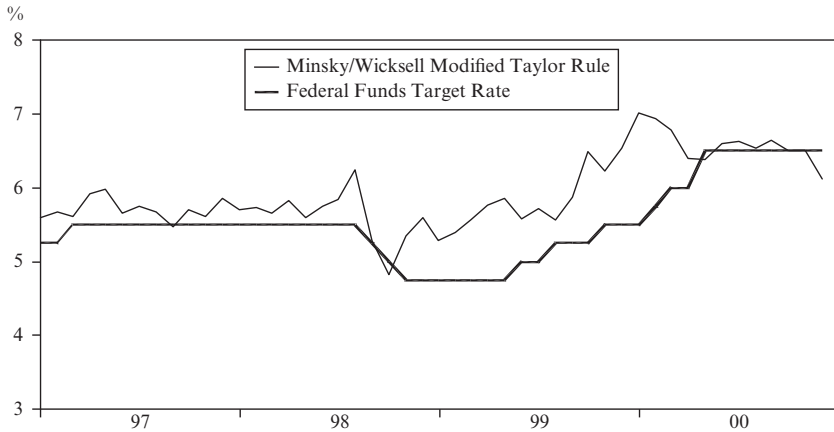

Note: Wicksell rates. Jan.–July or 1997 are estimated. No TIPS existed, therefore interpolation was necessary.

Figure 7.11 *The Minsky/Wicksell modified Taylor rule judges 1997–99 as an easy money episode*

to failure. At crucial moments like 1998, 2001 through 2002 and 2007 through 2008 the Fed needs to actively ease to counter system wide risks in an increasingly bearish backdrop.

This brings us back to Alan Greenspan and monetary policy over the decade. In both words and actions Alan Greenspan, in moments of crisis, made it clear that he was willing to reject market assessments. Unwarranted fears were met by aggressive ease. How, then, do we square these actions with Greenspan's oft articulated refusal to out think market judgments on the way up? Greenspan, with a straight face and no cigar smoke, insisted that the Fed had no tools available to judge whether markets were moving toward excesses.

It is at this juncture, we believe, that our MWMTR becomes most useful. By introducing spreads to the Taylor Rule we see that Minsky insight giveth and taketh away. From 1997 through 1999, super tight credit spreads implied higher fed funds than the rates that were in place (see Figure 7.11). Likewise, the pace of interest rate increase implied by the MWMTR, 2003 through 2005, was much quicker than the actual rise for fed funds (see Figure 7.12).

What, then, does our MWMTR tell us? What most of us have known for some time. The Greenspan-led Fed had an asymmetric attitude toward efficient markets. It applied no resistance to markets when they wanted to go up. It countermanded market forces, when players' actions were

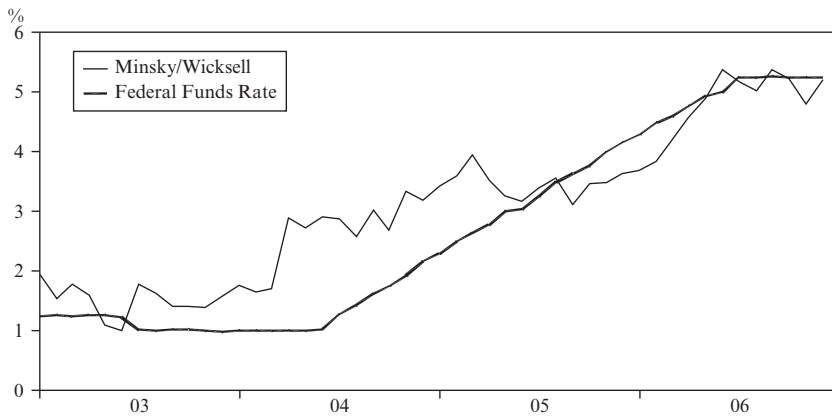

*Figure 7.12 The Minsky/Wicksell modified Taylor rule suggests that Fed tightening, 2003–05, was delayed*

pushing markets down. This asymmetry invited moral hazard. And some of the woes in place in 2008, no doubt were a consequence of this schizophrenia about rational markets.

### **Toward a more expansive definition of ‘excess’**

Stepping back from the particular dynamics of the decade 1998–2008 in the US we know history tells us that destabilizing imbalances in an economy can arise with little or no wage or price inflation. Wage and price pressures were absent in the US in the 1920s. In Japan, in the years leading up to 1990, inflation, excluding energy, remained moderate. Nonetheless, the US economy in the 1930s and the Japanese economy in the 1990s suffered extraordinary setbacks. In both cases spectacular asset price increases traveled hand in hand with inflation free booms. Subsequently, asset price implosions doomed each economy to a decade of economic contraction and price deflation.

A central bank exclusively focused upon wages and prices would have failed to react to the excesses that developed in the US in the late 1920s and in Japan in the late 1980s. Therefore, asset price excess, despite its devilishly hard identification, must be one of the excesses that a central bank pays attention to.

Alan Greenspan, to be sure, rejected this view during his tenure at the US Fed. And Ben Bernanke, during the 2003–06 run up for house prices, extended Greenspan’s policy of refusing to outguess market judgments. Their collective refusal is completely consistent with mainstream economic theory. Financial markets set prices based upon investors’ willingness



to wager their own financial fortunes. As the saying goes, the forecasts embedded in financial markets ‘are the best forecasts money can buy’.

But the Greenspan/Bernanke era, because it refused to respond to financial system excesses, until they revealed themselves in real economy pressures, oversaw a succession of asset market bubbles that required increasingly large financial system rescue operations. The blind spot in Federal Reserve Board thinking, unfortunately, reflects deep-seated economic ideology. Economists at the Fed, on Wall Street and in other economic policy jobs, embrace the idea that market forces lead us in the right direction. To acknowledge that the free flow of money in a capitalist system leads inexorably to excess and recession, on the face of it, sounds like a fantastic economic heresy. It need not be. How hard is it to say these words?

Capitalism is the best economic system. But it is not perfect. Its bias toward taking ever greater risks, as expansions age, requires Central Bank action, just as its periodic flight from risky endeavors also demands central bank action.

In simplest terms, Fed policymakers must be willing to take a pragmatic approach to asset markets, responding to giddy markets on the way up as well as despondent markets as prices come crashing down. Embracing essential Minsky insights across the business cycle, rather than only during crisis moments, makes good economic sense.

To suggest, however, that strict adherence to our MWMTR will prevent future episodes of financial system excess is, of course, absurd. Minsky’s greatest insight was appreciation of the paradox of Goldilocks. Benign real economy circumstances invite financial innovation, increased leverage, and ultimately financial instability. But the amplitudes of asset market boom–bust cycles, may be tempered, somewhat, if Fed officials are willing to respond to financial system signals both on the way down and on the way up. It’s the right moment to embrace the Minsky model.

## Bibliography

- Barbera, R.J. and Charles L. Weise (2008), ‘Has Greenspan’s conundrum morphed into Bernanke’s calamity? A Minsky/Wicksell modified Taylor rule’, in *Conference Proceedings: 17th Annual Hyman P. Minsky Conference on the State of the U.S. and World Economies*, Levy Economics Institute of Bard College, Annandale-on-Hudson, New York, April.
- Greenspan, A. (2000), ‘Technological innovation and the economy’, Keynote Speech, The White House Conference on the New Economy, Washington DC.
- Krugman, P. (2002), ‘My economic plan’, *New York Times* (October 4), p. 27.
- Mehrling, P. (2000), ‘Minsky and modern finance’, *Journal of Portfolio Management*, (Winter), 81–8.
- Mencken, H.L. (1927), *Selected Prejudices*, New York: A.A. Knopf.
- Minsky, H.P. (1975), *John Maynard Keynes*, New York: Columbia University Press.
- Minsky, H.P. (1986), *Stabilizing an Unstable Economy: A Twentieth Century Fund Report*, New Haven and London: Yale University Press.

- Taylor, J.B. (1993), 'Discretion versus policy rules in practice', *Carnegie-Rochester Series on Public Policy*, **39**, 195–214.
- Tymoigne, E. (2006), 'The Minskyan system, Part I', Working Paper No. 452, Levy Economics Institute of Bard College, Annandale-on-Hudson, New York.
- Weise, C.L. (2007), 'A simple Wicksellian macroeconomic model', *The B.E. Journal of Macroeconomics*, **7**(1), 214–33.
- Weise, C.L. and R.J. Barbera (2009) 'Minsky meet Wicksell: using the Wicksellian model to understand the twenty-first century business cycle', in G. Fontana and M. Setterfield (eds), *Macroeconomic Theory and Macroeconomic Pedagogy*, London and New York: Palgrave Macmillan, forthcoming.
- Wray, L.R. (2007), 'Lessons from the subprime meltdown', Working Paper No. 522, The Levy Economics Institute of Bard College, Annandale-on-Hudson, New York.

### Appendix 7A: Taylor Rule equations

- Taylor's original formula (Taylor 1993):

$$f_t^{TR} = (\pi_{t,12} + 0.5 * (\pi_{t,12} - 2) + 0.5 * (y^* - y_t) + 2 \quad (7A.1)$$

- Taylor's equation modified using NAIRU, invoking Okun's Law (Figure 7.1):

$$f_t^{TR} = (\pi_{t,12} + 0.5 * (\pi_{t,12} - 2) + (u^* - u_t) + 2 \quad (7A.2)$$

- Taylor modified equation, using core CPI (Figure 7.2):

$$f_t^{TR} = (\pi_{t,12}^c + 0.5 * (\pi_{t,12}^c - 2) + (u^* - u_t) + 2 \quad (7A.3)$$

- Taylor equation, additionally modified replacing '2' with Wicksellian natural rate (Figure 7.6):

$$f_t^{TR} = \pi_{t,12}^c + 0.5 * (\pi_{t,12}^c - 2) + (u^* - u_t) + w - (\tau + 0) \quad (7A.4)$$

Taylor equation, finally modified, adding a Minsky 'risk' term (Figure 7.8):

$$f_t^{TR} = (\pi_{t,12}^c + 0.5 * (\pi_{t,12}^c - 2) + (u^* - u_t) + w - (\tau + 0) - \eta \quad (7A.5)$$

(Where  $\eta \equiv S - \sigma$ )

where:

- $f_t^{TR}$   $\equiv$  Target rate for Fed funds in period  $t$
- $\pi_{t,12}$   $\equiv$  Year-on-year change in CPI, in period  $t$
- $\pi_{t,12}^c$   $\equiv$  Year-on-year change in core CPI, in period  $t$

$y^*$   $\equiv$  Potential GDP

$y_t^*$   $\equiv$  GDP in period  $t$

$u^*$  *NAIRU*

$u_t$   $\equiv$  Jobless rate, in period  $t$

$W$   $\equiv$  Wicksellian natural rate

$$W = (2(10\text{-year TIPS yield}) - 5\text{-year TIPS yield}) + \sigma$$

$$= 5\text{-year forward TIPS yield} + 1.8 \equiv \text{Neutral risky/risk free spread}$$

$\sigma$  = Average risk premium (Baa corporate bond rate – 10-year Treasury (1960–2008)) = 1.8

$\tau$   $\equiv$  Average term premium (10-year rate minus Fed funds rate, 1960–2008) = 0.8

$S$   $\equiv$  BAA corporate minus 10-year Treasury rate

$\eta$   $\equiv S - \sigma$ .